

Manual for Disctype Membrane Module

Type: DTRO/HPDTRO/DTNF

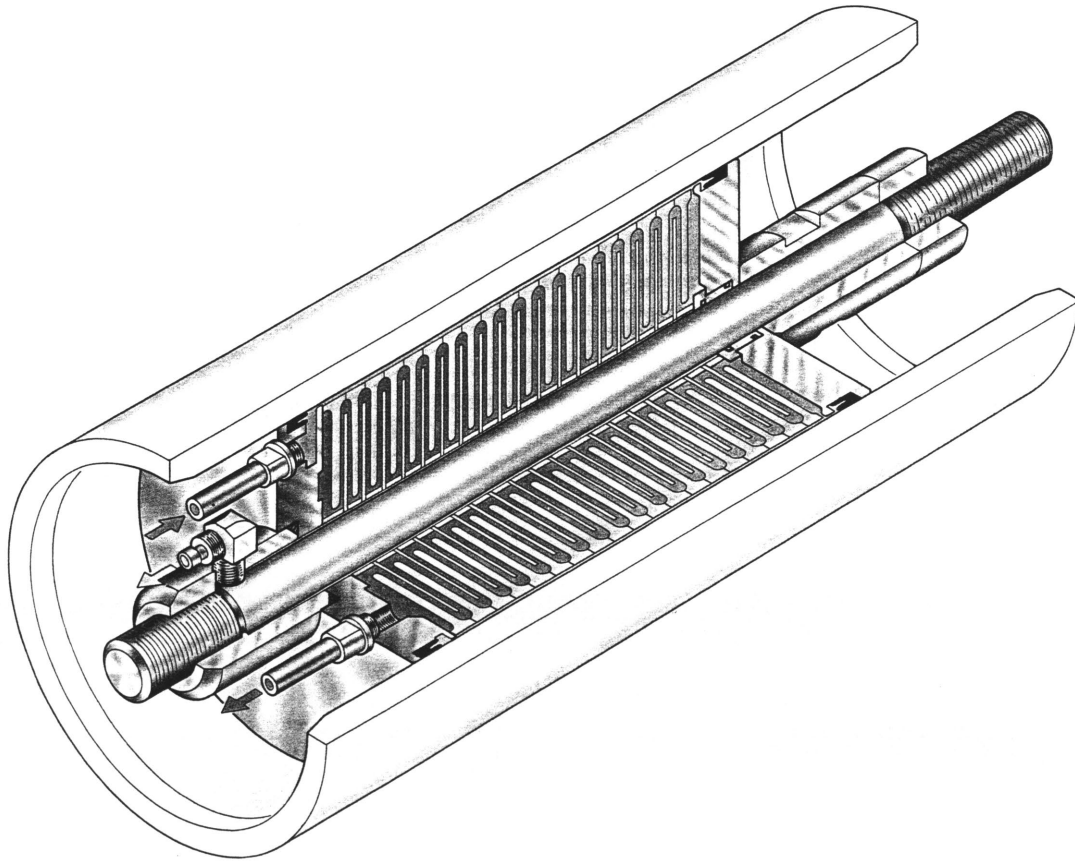

Contents

1. NOMENCLATURE FOR MEMBRANE MODULES	3
1.1 DECODING OF THE PRODUCT CODE.....	3
1.2 PRESSURE RATING FOR MEMBRANE MODULE	3
1.3 MEMBRANE MODULE TYPE AND CATEGORY	3
1.4 MEMBRANE CATEGORY	3
1.5 MEMBRANE AREA	4
1.6 THE MATERIAL OF FEED INLET.....	4
1.7 EXAMPLE OF NOMENCLATURE	4
2. MEMBRANE MODULE INSTALLATION SIZE AND STRUCTURE.....	5
2.1 INSTALLATION SIZE	5
2.2 COMPONENTS	6
2.3 MEMBRANE MODULE STRUCTURE DESCRIPTION.....	7
2.4 WATER FLOW DIRECTION INSIDE THE MEMBRANE MODULE	8
3. MEMBRANE MODULE USING	10
3.1 OPERATING PARAMETER REQUIREMENTS	10
3.2 NOTES.....	10
4. MEMBRANE MODULE MAINTENANCE.....	11
4.1 CHECKING TORQUE	11
4.2 CHEMICAL CLEANING	12
4.3 CLEANING AGENT	12
4.4 CLEANING PROCEDURES.....	14
4.5 MEMBRANE PRESERVATION.....	14
4.6 MEMBRANE MODULE STORAGE TIME	15
4.7 MEMBRANE CUSHION PRESERVATION.....	15
5. MEMBRANE MODULE REPAIR	16
5.1. MEMBRANE CASING LEAKAGE	16
5.2. MEMBRANE MODULE REPAIR	16
5.3. THE FOLLOWING ADDITIONAL POINTS MUST BE NOTED.....	22
6. QUALITY ASSURANCE AND AFTER-SALES SERVICE	23

1. Nomenclature for Membrane Modules

1.1 Decoding of the product code

The code of the disc-type membrane module is composed of five parts: module pressure rating, module type and category, membrane category, membrane area and material of feed inlet. Each part is connected with a hyphen "-". The format of the five parts is as follows:

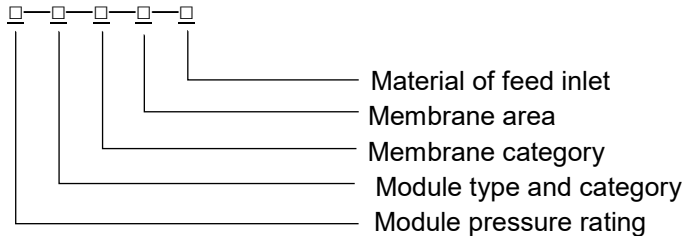

1.2 Pressure Rating for Membrane Module

According to the pressure level of the membrane module, disc-type membrane modules are divided into: Normal pressure, Medium pressure, High pressure. The coding is described by the English initial letter of the pressure level, and shown as Table 1.

Table 1 Coding for Proof pressure

Description	Code
Normal pressure (Operating pressure ≤ 75 bar)	NP
Medium pressure (Operating pressure ≤ 90 bar)	MP
High pressure (Operating pressure ≤ 160 bar)	HP

1.3 Membrane Module Type and Category

According to the structure of the membrane module, it is divided into: disc-type membrane module. The category code is described by the capital abbreviation of the English name of the module, shown as in Table 2.

Table 2 Module Category

Type and category	Coding
Disc-type membrane module	DT

1.4 Membrane category

The performance of the membrane filtration is shown as in Table 3

Table 3 The performance of the membrane filtration

The performance of the membrane filtration	Coding
Nano-filtration with High desalination rate	NF1
Nano-filtration with High flux	NF2
Nano-filtration with High selectivity	NF3
Reverse Osmosis with Medium desalination rate and high flux	RO3
Reverse Osmosis with high desalination rate and high flux	RO4
Reverse Osmosis with high desalination rate and high temperature resistance	RO6

1.5 Membrane area

The effective membrane area of the module is expressed in Arabic numerals, and the unit is m².

1.6 The material of feed inlet

Table 4 Coding for the material of feed inlet

Material of feed inlet	Coding
Made of Stainless steel SS316L	SS316L
Made of Duplex stainless steel SS2205	SS2205
Made of Super duplex stainless steel SS2507	SS2507

1.7 Example of nomenclature

NP-DT-RO3-9.405-SS316L

Normal pressure module, pressure rating is 75bar; membrane type is RO3; Membrane performance is Medium desalination rate and high flux; membrane area is 9.405 m², the material of feed drainage are made of SS316L stainless steel.

When the pressure rating code is not mentioned, the default pressure level is 90bar.

When the separation performance index code is not mentioned, the default data will be reverse osmosis with the high desalination rate and high flux (RO4).

When the membrane area is not shown, the default membrane area is 9.405 m².

When the material of the feed inlet is not reflected, the default material is SS316L stainless steel.

2. Membrane Module Installation Size and Structure

2.1 Installation Size

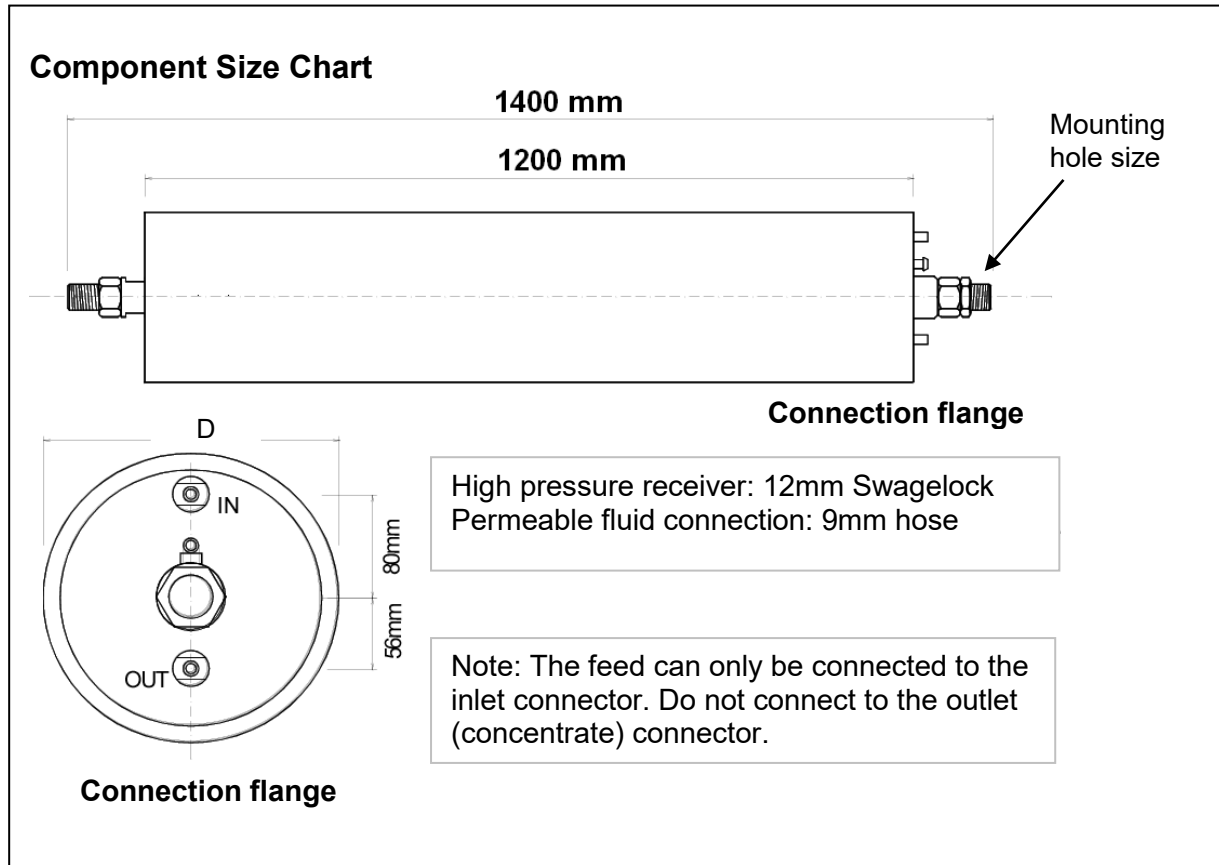
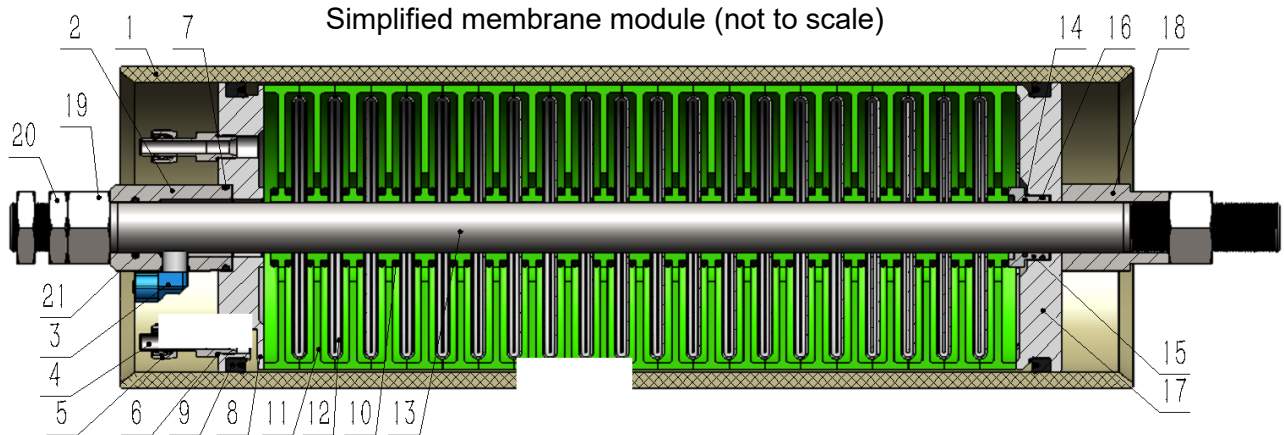

Table 5 Disc-tube membrane module size and weight

Name	Diameter (mm)	Size tolerance (mm)	Installation hole size d (mm)	Dry weight (KG)
Normal Pressure (NP)	216	±2.0	φ36.0	60
Medium pressure (MP)	220	±2.0	φ36.0	75
High pressure (HP)	238	±2.0	φ46.0	100

2.2 Components



No	Component Number	Name	Material	Qty	Unit	Remark
1	71510002/71510003	Pressure vessel	FRP	1	pc	MP/HP
2	81111001/81111002	Permeate collector	2205	1	pc	MP/HP
3	71160001	Permeate elbow	POM	1	pc	MP/HP
4	81114003	High pressure connection	2205	2	pc	MP/HP
5	72013901	Union nut	SS316L	2	pc	MP/HP
6	71210002	O-ring HP-connection	NBR	2	pc	MP/HP
7	71210003/71210008	O-ring Perm. Collector - outside	NBR	1	pc	MP/HP
8	72010002/72010004	Connection-Flange	SS316L	1	pc	MP/HP
9	71211001/71211002	Flange - Lip Seal	EPDM/PU	2	pc	MP/HP
10	71210001	O-ring hydraulic disc	NBR	420	pc	MP
	71210007	O-ring hydraulic disc	NBR	396	pc	HP
11	71110001	Hydraulic-Disc	ABS	210	pc	MP
	71110003	Hydraulic-Disc	POM	198	pc	HP
12	810-----	Membrane cushion	RO3/RO4/ NF3	209	pc	MP
	810-----	Membrane cushion	RO4	197	pc	HP
13	81113001/81113002	Tie rod	14Cr17Ni2	1	pc	MP/HP
14	71210005/71210010	O-ring Seal bush- inside	NBR	1	pc	MP/HP
15	81112001/81112002	Seal bush	2205	1	pc	MP/HP
16	71210004/71210009	O-ring Seal bush- outside	NBR	1	pc	MP/HP
17	72010001/72010003	End flange	SS316L	1	pc	MP/HP
18	81110001/81110002	Tie rod spacer	2205	1	pc	MP/HP
19	72011001/72011003	Lock nut - full	35CrMo	2	pc	MP/HP
20	72011002/72011004	Lock nut - half	35CrMo	2	pc	MP/HP
21	71210006/71210011	O-ring Perm. Collector - inside	NBR	1	pc	MP/HP

2.3 Membrane module structure description

Rather than using scale drawings, the following description of the module has been made in sketch form. Please note that the following drawings are not to scale. The purpose is to make it easier to see and understand.

The sketch below shows the main components of the module.

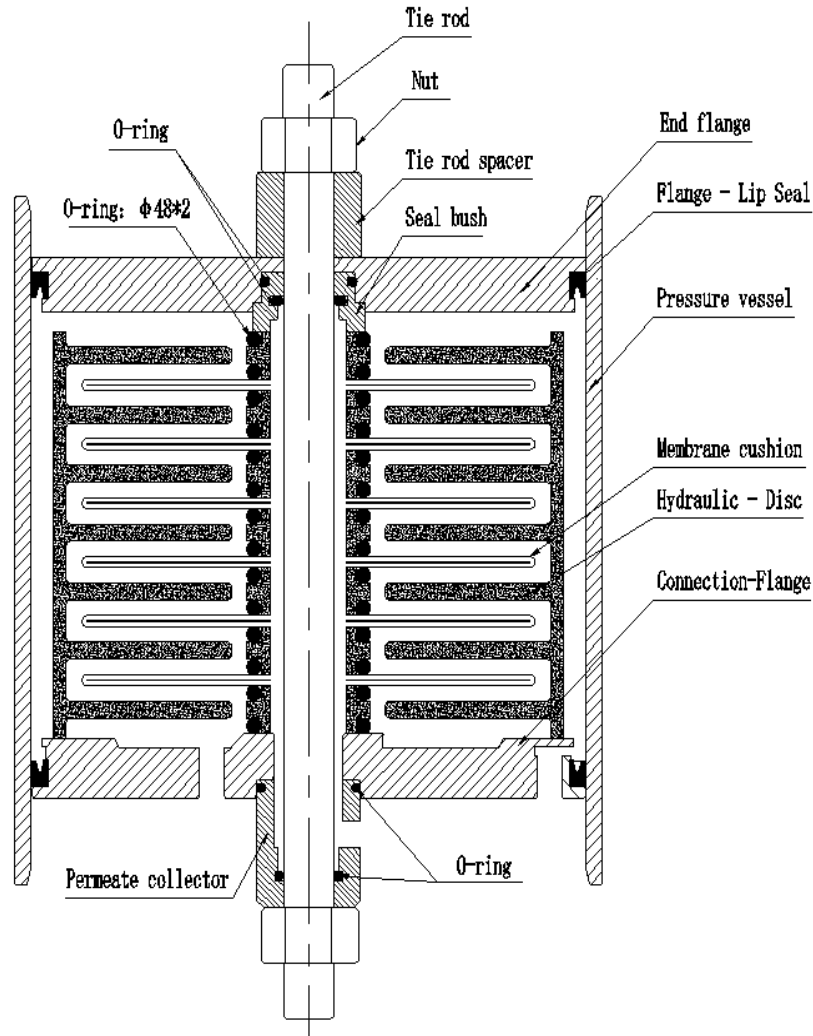

There are a total of 6 seals in the module, NOTE: All seals are different in dimensions.

One seal is a Flange-Lip Seal to prevent leakage from the pressure vessel.

Each hydraulic disc is fitted with 2 O-rings of the same size.

There are another 4 different sized O-rings for sealing around the Tie rod and flanges, the O-rings are shown below

O-ring: Prevent the permeate leak from tie rod

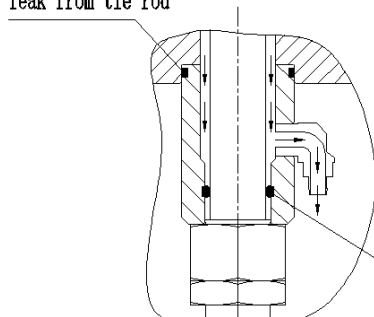

O-ring: Prevent the permeate leak from the tie rod

O-ring: Prevent the permeate leak from the end flange

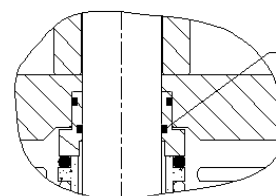

2.4 Water flow direction inside the membrane module

Flow path through the flow

Feed water is distributed into the pressure vessel through the inlet port. It flows down a passage between the disc stack and the pressure vessel.

At the end flange water passes through 8 channels allowing it to enter the chamber under the bottom hydraulic disc. From this chamber the water passes through the ports/slots in the bottom hydraulic disc which then directs the flow over the membrane cushions to the next hydraulic disc and through the next hydraulic disc port.

The feed water is prevented from escaping from the pressure vessel by the 2 lip seals fitted to the connection flange and the end flange.

As the feed flows over the membrane cushions "pure water" passes through the membrane and is carried away to the permeate collector.

Feed is prevented from entering the permeate area by the O-rings fitted to the hydraulic discs.

As the pure water is being removed from the feed, the feed becomes more concentrated in suspended and dissolved solids.

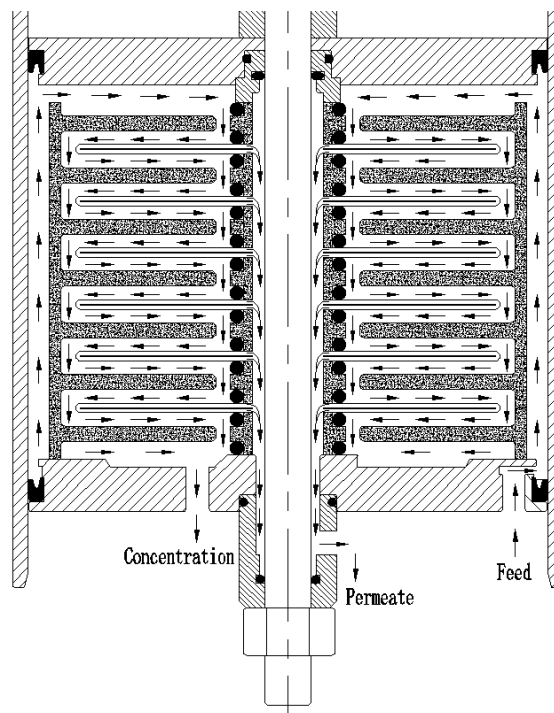

Flow through the module

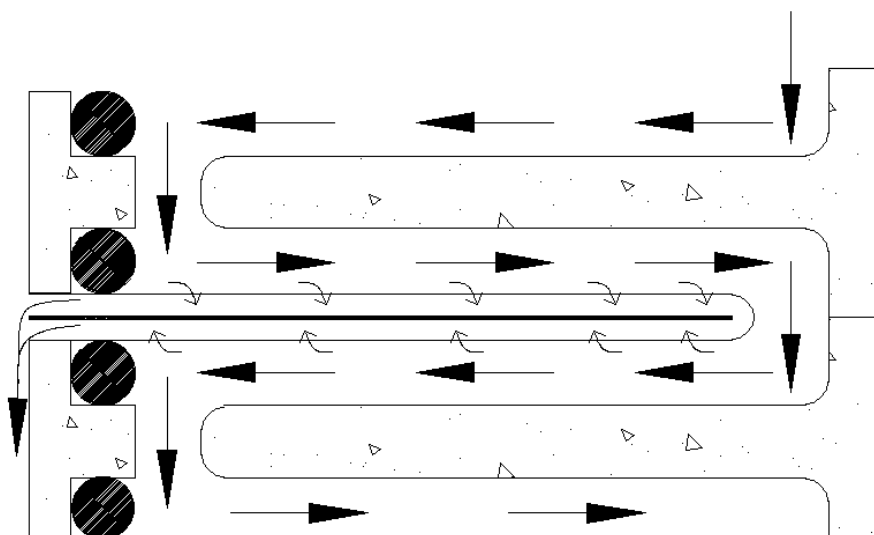

Above enlarged section, shows the feed flowing over the membrane cushion, pure water permeate through the membrane cushion and is carried by the fleece sheet within the membrane cushion into the permeate channels. The O-rings on the hydraulic discs prevent the feed from entering the permeate channels.

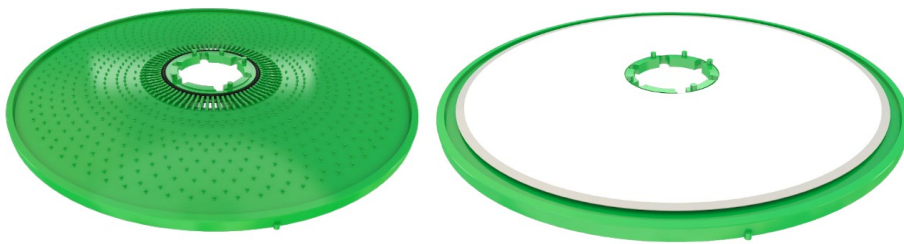

The above picture shows a hydraulic disc with the O-ring. The other picture shows the hydraulic disc fitted with a membrane cushion.

The Membrane Cushion consists of a fleece sheet between 2 membranes.

The outer edges of the membrane cushion are sealed by ultrasonic welding.

The surfaces of the membrane cushion are delicate and care must be taken when handling them.

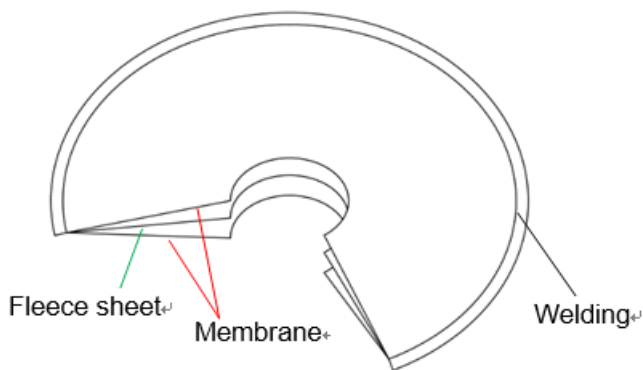

Section of hydraulic disc

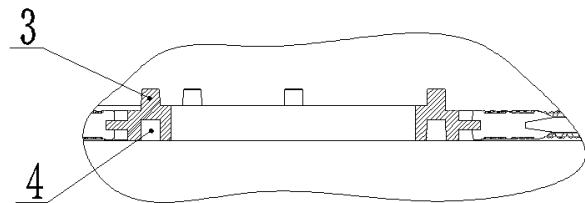
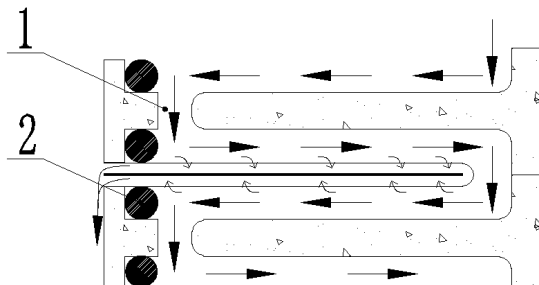

1、 Flow path through disc 2、 O-ring seal

3、 Support pins 4、 Alignment pin locating holes

3. Membrane module using



Mechanical hazard!

The membrane module is under high pressure during operation, so do not disassemble it. The membrane module must be disassembled and repaired after all equipment in the system is shut down and no pressure in the pipeline connected to the membrane module is ensured.



3.1 Operating parameter requirements

- (1) Feeding flow: 0.5-1.0m³/h, depending on water quality.
- (2) pH range: 3-10, 2-12 when cleaning.
- (3) Temperature range: 5-45°C.
- (4) Operating pressure: depending on the product model, NP type≤75bar; MP type≤90bar; HP type≤160bar

3.2 Notes

- (1) Membrane Module Arrival
When you receive the membrane module, please carefully check whether the outer packaging is damaged. If there is any damage, please notify us in time.
- (2) Storage
Stored in an environment of 5-30°C, the humidity does not exceed 70%, and is not exposed to direct sunlight or other ultraviolet light sources. The new membrane in the original package can be stored for half a year.
- (3) Installation
Before installing the membrane module, flush the equipment with clean water; make sure that the equipment does not contain hard solid particles such as welding slag to damage the membrane module; when installing the membrane module, you can use water, membrane cleaning solution or glycerin as a lubricant.
- (4) First using
It takes about 15 minutes to flushing for the first using.
- (5) Normal using
For the raw water quality, a suitable pretreatment process is adopted to avoid physical blockage of the membrane module.
During normal using, the valve should be prevented from being opened or closed suddenly too quickly, as the water hammer may damage the membrane.
The membrane should be kept operating under the recommended operating parameters and should not exceed the operating pH, temperature, pressure and differential pressure ranges of the membrane.
Disc-tube membrane modules are forbidden to backwash, and the dialysate side should not be held back.
- (6) Cleaning
After the membrane flux drops, it must be recovered by chemical cleaning in time. We recommend using professional membrane cleaners from membrane manufacturers.
- (7) Stop and save
If the system needs to be shut down for more than 3 hours, the membrane module should be flushed and filled with clean water.
If the system is shutting down for more than 24 hours, the system should be flushed and protected with sodium bisulfite solution, and the protection liquid should be replaced weekly.
Note: It is best to use deionized water for the flushing and cleaning of membrane modules. If this is not possible, use softened water. Tap water with high hardness and alkalinity may cause new pollution to the membrane module during the cleaning process.

4. Membrane module maintenance

Mechanical hazard!	
	The membrane module is under high pressure during operation, so do not disassemble it. The membrane module must be disassembled and repaired after all equipment in the system is shut down and no pressure in the pipeline connected to the membrane module is ensured.
	The torque load on the component must be maintained at 100-110N.M (HP: 140N.M), otherwise it will cause damage to the membrane and hydraulic disc. Torque tightening must be performed after chemical cleaning, at which time the components should be in a shutdown state.
	The components must be carried out in accordance with the cleaning instructions, otherwise the performance of the components will be affected and the service life of the membrane will be reduced.

4.1 Checking Torque

Checking Torque loading

The torque loading on the tie rod of the DT modules should be checked and corrected as follow:

- Before trial running
- After the first week of operation, during shutdown
- Once in operation every two weeks, each time after the chemical cleaning.

Note: Unit must be stopped and modules must be pressure free when checking torque. Module do not require to be removal from their mounting for this procedure.

If the torque loading is not checked and corrected then the permeate quality may change and damage will be caused by one of the hydraulic disc"O" rings being displaced.

<p>DTRO/DTNF Tools Required: 50 mm long socket 10-150Nm torque wrench 50 mm open end spanner Molykote grease</p>	<p>HPDTRO Tools Required: 70 mm long socket 10-150Nm torque wrench 70mm open end spanner Molykote grease</p>
---	---

<p><u>Vertical Mounted Modules</u> Check that the bottom nut securing the module to the bottom frame is tight.</p>	<p><u>Horizontal Mounted Modules</u> Check that the nut securing the module to the frame is tight,(the nut on the outside of the vertical frame).</p>
---	--



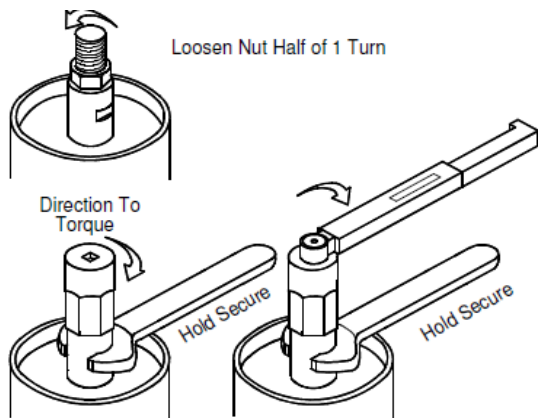

- 1-Fit (MP)50mm/(HP)70mm spanner to distance fitting and hold in this position.
- 2- Loosen nut by half a turn to ensure that nut is not seized.
- 3- MP: Torque nut to 100NM, HP: Torque nut to 140NM whilst not allowing the distance fitting to turn.
- 4- Check torque loading 3 times to ensure correct loading.
- 5-Grease tie rod thread and nut with Molykote and replace protective cap.

NOTE 1:

100 Nm = 10 Kpm = 72 Lb.Ft



4.2 Chemical cleaning

	<p>DO NOT MIX VARIOUS CLEANING AGENTS! IF USED IN COMBINATION, IT WILL ONLY NEUTRALIZE THE CLEANING SOLUTION, MINIMIZE THE CLEANING EFFECT, AND ALSO DAMAGE THE MEMBRANE SURFACE.</p>
	<p>DO NOT USE CLEANING AGENTS CONTAINING OXIDANTS, AS OXIDANTS WILL CAUSE PERMANENT DAMAGE TO THE FILTER MEMBRANE. (SUCH AS FREE CHLORINE, CHLORINE, OZONE, ETC.)</p>
	<p>Do not clean the filter membrane by hand or other soft tools that affect the filtration performance of the membrane surface and make the membrane material lose its desalination ability.</p>
	<p>It is recommended to use deionized water for cleaning and preservation to achieve the cleaning effect.</p>

4.3 Cleaning agent

Type of cleaning agent Parameters and functions	Enzyme cleaning agent	Alkaline cleaning agent	Acid cleaning agent
Preparation of cleaning agent	0.25-1.0%W/W JIARONG EP Type cleaning agent solution ;	0.25-1.0%W/W JIARONG CP120 Type cleaning agent solution ;	0.25-1.0%W/W JIARONG AP310 Type cleaning agent solution ;
Cleaning conditions	Circulating for 60-90 minutes under the conditions of Ph8.0-8.5 and temperature of 30-40°C ;	Adjusting the cleaning solution to PH=10-11 and circulating for 60-90 minutes at 30-40°C.	Adjusting the acid cleaning agent to pH=3-4, and circulating at 30-40°C for 60-90 minutes.

Cleaning effect	Removal of pollution on the membrane surface for organic matter, sludge, sugar, slime mold	Removal of pollution on the membrane surface for organic matter, sludge, sugar, slime mold	Removal of pollution on the membrane surface, for inorganic salts and metal precipitation
Judge cleaning standard and cleaning times	1) The standard flux drops to 10-15% of the initial flux (or the standard flux after the last chemical cleaning); ; 2) The pressure drop in and out of the membrane increases to 10-15% of the initial pressure drop (or the standard pressure drop after the last chemical cleaning); 3) The membrane rejection rate drops to 10-15% of the initial rejection rate (or the standard rejection rate after the last chemical cleaning).		

The harm of pharmaceuticals to human health and the environment

Inhaling or swallowing chemical cleaning agents can cause damage to the human body, resulting in burns and bronchitis.
 Direct contact with chemical cleaning agents may cause temporary physical discomfort (coughing), breathing difficulty, and eye burns.
 Hazardous to water-avoid entering surface water and sewage!

Cleaning protection measures and code of conduct

<p>Strictly follow the instructions of the cleaning agent manufacturer and make various preparations and protections!</p> <p>Ensure good ventilation during operation, be careful when opening the seal, seal the container immediately after use, and limit each storage volume to one shift to avoid contact with eyes, skin and clothing.</p> <p>Measures must be taken to protect the skin. After use, the residue on your hands should be removed immediately, and your hands must be washed thoroughly after finishing the work and before each work break to avoid splashing.</p> <p>Use skin care agents, change wet clothes immediately, change clothes immediately after finishing work, and store casual clothes and work clothes separately. Observe the restrictions regulation of the job!</p> <p>Eye protection: Goggles must be worn. If there is a risk of splashing, wear face shields and goggles.</p> <p>Hand protection: Gloves must be made of natural rubber, neoprene, nitrile rubber, butyl rubber and fluorinated rubber. It is recommended to wear cotton gloves under protective gloves.</p> <p>Respiratory protection: wear particulate filter P2 (white)</p> <p>Skin protection: Use skin care cream suitable for all exposed parts of the body.</p> <p>Body protection: Wear alkali-resistant protective clothing, and wear a plastic apron when diluting or filling.</p>	
---	---

Accident first aid

<p>In any emergency procedure, you should first protect yourself and then notify the doctor immediately.</p> <p>After contact with eyes: rinse with water or eyewash solution for ten minutes.</p> <p>After contact with the skin: immediately take off the contaminated clothes, rinse with</p>	
---	---

<p>plenty of soap and water, and rinse with water for 15 minutes after burns. After inhaling the respiratory tract: fresh air, keep the ventilation holes unblocked, remove the dentures, and throw up the vomit. If breathing or heartbeat stops, immediately use artificial respiration and cardiac massage. After swallowing the esophagus: Do not use household medicine, do not let him vomit, if he is still conscious, try to make him drink plenty of water, a little at a time.</p>	
---	--

4.4 Cleaning procedures

Matters needing attention when cleaning:

Before cleaning, the residual material in the system should be ejected out of the system with deionized water: before the end of production, fill the cleaning tank with water, start the equipment, and turn off the equipment after the system top cleaning from the concentrate. .

Standardized measurement of water flux to determine whether chemical cleaning is required: switch the system to the state of cleaning valves, that is, the concentrate and permeate are returned to the CIP tank for circulation, start the equipment, and control the pressure at 20 bar. When the deionized water runs stably, record the permeate flow rate at this time is compared with the initial standardized membrane flux. If it drops to 85% of the initial value, it should be cleaned. .

Configure chemical cleaning agent: judge the pollutants according to the produced material liquid, select the cleaning formula for the pollutants (see the cleaning agent table), and prepare the cleaning liquid according to the cleaning formula to the CIP tank.

Chemical cleaning: Start up and run according to the standardized method of measuring water flux, and clean according to the requirements of the cleaning plan.

After the cleaning is completed, use the standardized water flux to determine whether to continue chemical cleaning: rinse the system with deionized water, and measure the water flux according to the above-mentioned standard water flux measurement method. If the flux has been restored, the system will switch to In the next batch of production or standby mode, if it is not restored, the cleaning agent needs to be replaced to continue cleaning. If the cleaning fails to recover after multiple cleanings, you need to contact JIARONG to find a solution.

Cleaning program

Step	Operation	Concentration	Temperature (°C)	Time (min)
1	Water Wash	Hot water	35-40	15-30
2	Medicine wash	According to the cleaning agent instructions, if the pH value changes greatly during the cleaning process, it is necessary to add a cleaning agent to maintain the cleaning pH value	30-40	60-90
3	Flushing	Deionized water	Room temperature	15-30

During the cleaning process, the pH value should be monitored. Cleaning with AP cleaning agent requires a pH value of not less than 11.5. However, in order to protect the components from damage, the pH value must not exceed 12.

The temperature at the end of the cleaning must reach 40°C.

4.5 Membrane preservation

Since the membrane mudules are organic materials, the propagation of bacteria on the membrane surface will damage the active layer on the membrane surface, resulting in the loss of membrane performance. Therefore, if the membrane equipment is to be shut down for a period of time, different protective solutions

can be prepared and stored in the system according to the time of shutdown. It prevents the growth and reproduction of bacteria.

	<p>WARNING!</p> <p>Once the membrane module is soaked in water and wet, it should always be kept in a wet state and it is forbidden to dry out, otherwise the membrane will be damaged and the membrane warranty clause will be invalid!</p>
---	---

4.6 Membrane module storage time



Maximum storage time	Protection solution
3days	Fill the modules with deionized water
7days	The 0.1% W/W sodium bisulfite solution is circulated for 30 minutes at 10-25°C.
30days	The 0.25%W/W sodium bisulfite solution is circulated for 30 minutes at 10-25°C.
12months	0.25%V/V cassone solution plus 18%V/V glycerol (98% reagent grade). When fully mixed, circulate at 10-25°C for 60 minutes.

4.7 Membrane cushion preservation

- (1) The dry membrane should be packed in a sealed plastic package, and placed in a cool and dry place indoors, at a storage temperature of 5°C-30°C, and should be protected from direct sunlight.
- (2) The wet membrane should be stored in 1% food grade sodium bisulfite standard protective liquid: soak the membrane in the standard protective liquid for 1 hour, and then place the membrane in a plastic bag that can isolate oxygen, It is not necessary to pour too much protective liquid into the plastic bag, just to ensure the moisture content of the membrane. Storage temperature 5°C -30°C.

→ Cleaning modules and checking torque are the two main maintenance tasks ←

5. Membrane module repair

	Mechanical Hazard!
	The membrane module is under high pressure during operation, so do not disassemble it. The membrane module must be disassembled and repaired after all equipment in the system is shut down and no pressure in the pipeline connected to the membrane module is ensured.
	Before repairing the module, clean the sewage in the membrane module with clean water. Maintenance personnel should wear goggles. Once sewage splashes into the eyes, rinse with plenty of water.

5.1. Membrane casing leakage

When the module feed pressure is released a vacuum is formed within the module, this sometimes causes the Lip Seal to open a little. If there are any small dirt particles around the seal they will possibly be sucked in and onto the sealing edge of the lip seal. When the module is pressurized after these dirt particles have been trapped in the lip seal, water may leak from the lip seal area.

To stop this leakage the following should be done:

Unit is stopped and pressure is off the modules.

Grip the edge of the pressure vessel and turn the pressure vessel 45 to 90°.

Restart unit, water may leak on start up but will stop before reaching working pressure.

When unit reaches working pressure stop and restart unit. On this next start up of the unit, no water should leak from the Flange - Lip Seal.

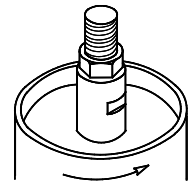

If the lip seal is still leaking then the following should be done

Remove the module (see later instructions) from the unit and remove the pressure vessel. Inspect the pressure vessel in area where the Flange - Lip Seal is in contact. See sketch, if any scratches or heavy black deposit areas are found remove these with either fine abrasive paper or ideally with a "Scotch Pad". Whilst the pressure vessel is removed inspect and clean the other end also.

Inspect the Flange - Lip Seal for small cuts/tears on the surface contact edge. If any are found replace this Flange - Lip Seal I with a new spare. Flange - Lip Seal Part No. MP/NP: 71211001; HP: 71211002

Rub some rubber lubricant or some soft soap on the Flange - Lip Seals and replace the pressure vessel and return the module to the unit.

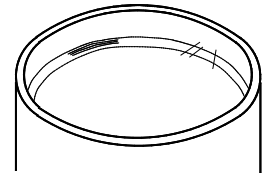

5.2. Membrane module repair

WARNING
<p>The 4 main causes of damage to the DT modules are:</p> <ul style="list-style-type: none"> a) Incorrect Torque b) Pressure On Permeate Discharge c) Vacuum in the feed or concentrae lines b) Incorrect flushing before first start up after service or repair.

Incorrect Torque

If the torque loading on the module tie rod is not maintained, then damage will occur because the hydraulic force from the bottom of the module will compact the Hydraulic-Discs and o-rings towards the inlet flange

Pressure on permeate discharge

When the unit is stopped there should never be any pressure in the permeate discharge line from the module. If this happens then some membrane cushions will inflate by the water pressure and be damaged in the following manner: they will pull free from the o-ring seals and be punctured by the support pins on the hydraulic discs. This will cause a high flow and poor quality in the permeate discharge.

Vacuum In The Feed Or Concentrate Lines

Vacuum on the feed or concentrate lines to and from the module will cause similar damage to that caused by pressure on the permeate discharge.

Incorrect flushing before first start up, after service or repair

After service or repair the unit must be flushed before start up. This procedure is recommended to de-aerate the module. Depend on quantity of modules it must proceed as long as air can be recognized in the system. Sometimes e.g. after complete change of modules it's necessary to operate the unit manually. If this can't be done by customer it should exclusively be carried out by UNISOL service engineer or under UNISOL assistance. Otherwise the warranty is lost.

Dismantling Modules

Tool required:

NP/MP:	Torque spanner	50mm socket	50mm Spanner	17mm Spanner	22mm Spanner
HP:	Torque spanner	70mm socket	70mm Spanner	17mm Spanner	22mm Spanner

Horizontal Mounted Modules

- Remove the high pressure hoses from the HP connections on the connection flange.
- Remove the permeate hose from the module connection elbow.
- Remove the nut securing the module to the frame.
- Remove the 2 cap screws and securing plate on the module frame.
- Remove spacer blocks from frame.
- Lift module out of frame by the tie rod ends. If handling module by the pressure vessel, care must be taken as the pressure vessel is not secured to the rest of the module.

Vertical mounted modules

- Remove the high pressure hoses from the HP connections on the connection flange.
- Remove the permeate hose from the module connection elbow.
- Remove the nut securing the module to the frame.
- Lift off module by using a lifting eye on the end of the tie rod. Do not lift off by holding the pressure vessel.

Dismantling Modules

To dismantle the DT modules, they first should be fixed in an upright position. On a frame similar to this one. This allows the module to be handled correctly and avoids the possibility of damage.

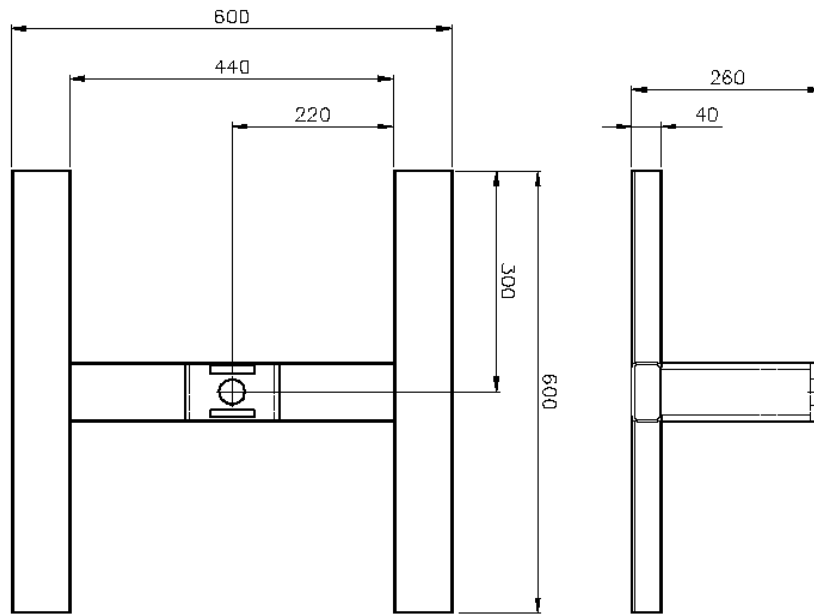

DT-Repair frame

After the DT module has been removed from its working position, screw it to the module repair frame as shown in fig.1.

Remove the pressure vessel by pulling it up and off, fig.1-fig.2. Wash down the exterior surfaces of the module stack. Clean and inspect the lip seals on the connection and end flanges.

Clean the pressure vessel inspect for scratches and deposits in the areas where the Flange - Lip Seals are in contact and remove any found.

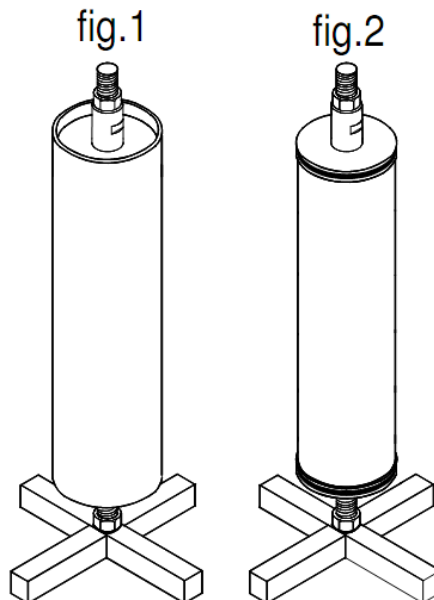

This is an operation that requires care, observation and patience when opening and especially when rebuilding the module stack.

Inspect the Hydraulic-Disc stack for any abnormalities that may look like one or more Hydraulic-Discs are distorted. Note this position i.e. between “XX” Hydraulic-Discs from the top. Hold distance piece secure and remove nut by turning anti clockwise see fig.3. Remove distance piece, it is normal for the Hydraulic-Discs stack to expand when the torque is released. See fig4. And fig.5.

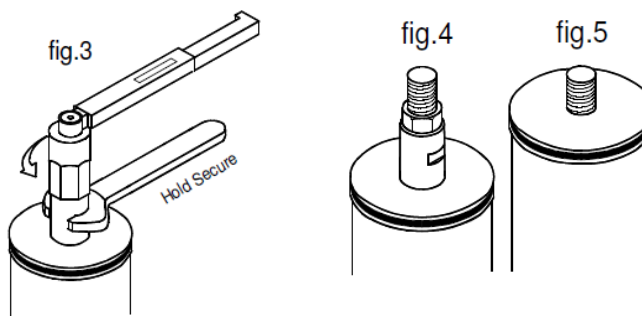

Before removing the end flange inspect again the disc stack. If any distorted Hydraulic-Discs were seen before the nut was undone then they should now be more prominent. Remove the end flange, clean it, and inspect the lip seal for deposits and damage. Place the end flange on a clean surface.

<p>To assist in verifying a blown O-ring in the area where disc distortion has been observed. Obtain a piece of straight wire 2mm diameter by 1,500mm long. Probe each of the 2 permeate channels until resistance is found mark this position on the rod and then transfer this mark to the outside of the membrane stack. Sometimes the O-ring has only been pushed out of position and not into the permeate channels, when this occurs, probing with a 2mm wire will not verify the position.</p>
<p>The most common place for a “blown O-ring” is within the first 10 Hydraulic-Discs from the top this should be checked and repaired as follows:</p>
<p>Carefully start to remove the first 10 Hydraulic-Discs and membrane cushions one at a time.</p>
<p>Place the Hydraulic-Discs on a clean surface. Layout the Hydraulic-Discs in a way that will allow you to replace them back in the same sequence as they were removed.</p>
<p>When removing a Hydraulic-Disc the O-ring may stick to the membrane chshion, if this happens carefully remove the membrane cushion and put it in a bucket of water with some A cleaner and allow to soak. After 20 minutes try to carefully remove the O-ring by “rolling” it off. If any surface material from the membrane cushion is adhering to the O-ring then this O-ring and membrane cushion must be replaced with new ones.</p>
<p>When the Hydraulic-Disc with the blown O-ring is found:</p> <ul style="list-style-type: none"> • Carefully inspect this Hydraulic-Disc and the one above for distortion, if suspect replace with new Hydraulic-Discs and O-ring. • This membrane cushion must be discarded and replaced with new one. • If any membrane cushions are seen to have pinholes made by the support pins on the hydraulic disc, then these must be replaced with new membrane cushions.
<p>Rebuild the module with the components that have been removed. Checking that:</p> <ul style="list-style-type: none"> • All O-ring are correctly seated. • Membrane cushions have no faults i.e. surface damage either in area where O-ring is in contact, surface scratches or small pinholes. • Discs are positioned correctly

When refitting the hydraulic discs check that the alignment is correct. On each Hydraulic-Disc on one side is a small cone shaped raised mark, on the opposite side there are 3 of them. The Hydraulic-Discs must align as shown in fig.6.

Refit the end flange and distance piece, you will most likely have to have assistance to push down the end flange to allow the nut to be put on.

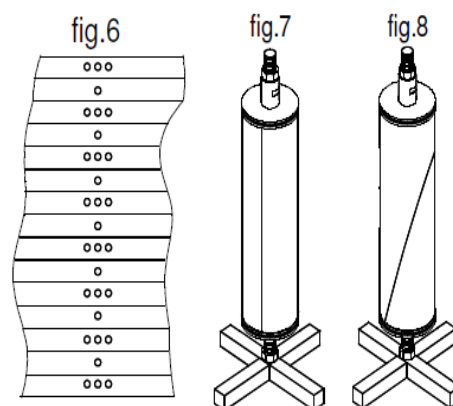

Before starting to tighten the nut check that the vertical alignment of the marks on the hydraulic discs are as shown in fig7, in a straight line NOT as shown in fig.8. The locating pins on the hydraulic discs could be broken off if the plates are twisted.

Whilst the tie rod nut is being torqued to MP: 100 Nm; HP: 120Nm do not allow the end flange to turn as this could twist the Hydraulic-Disc stack. Lubricate the Flange - Lip Seals lightly with soap and refit the pressure vessel. Return the module to the unit.

Full Dismantling

If a blown O-ring is not found in the first 10 Hydraulic-Discs or a blown O-ring has been found by probing with a wire then all Hydraulic-Discs or the Hydraulic-Discs down to the fault found have to be removed. If the fault is near the bottom then it is advisable to remove all Hydraulic-Discs. The following procedures should now be used:

Rebuild the 10 Hydraulic-Discs which were previously removed **ready** to be refitted to the module and place them to one side.

Remove the Hydraulic-Discs in groups of 20 down to the fault or completely and place them on a clean surface with them being “top down”.

They would now be upside down to the fitted position.

The reasoning for removing the Hydraulic-Discs in groups of 20 in twofold.

First, it is a volume that can easily be gripped between two hands and second, it makes it easier for rebuilding.

Count down to 20 Hydraulic-Discs and run your finger around to separate the stack at this point.

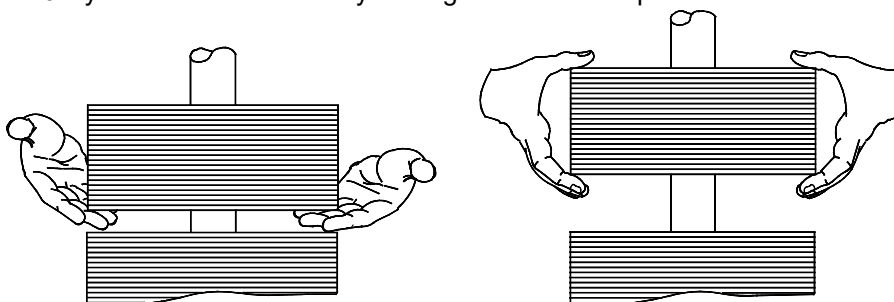

Grip this group together with both hands, one hand on either side and carefully remove from the tie rod. Place upside down in sequence as they should be refitted in the same position in the stack. i.e. first off is last on.

If when removing a group of hydraulic discs they are disturbed i.e.opened in the middle this group will have to be opened up to check if an O-ring or membrane has been displaced.

<p>If a blown O-ring is found more than half way down the Hydraulic-Disc stack then there is usually considerable damage, possibly up to 6 discs and membrane cushions damaged.</p>
<p>From this part the next instructions are broken into a further two parts, but all parts must be read. 1st part “Fault found by probing”; 2nd part “Fault not found in 1st 10 hydraulic discs”</p>
<p style="text-align: center;">For a blown O-ring found by probing then continue as follows:</p>
<p>Remove the Hydraulic-Discs in blocks of 20 until 4 Hydraulic-Discs above the fault.</p>
<p>When the fault is found examine also the hydraulic discs, membrane cushion and O-rings 3 above and 3 below the fault. Hydraulic discs should be examined and replaced if distorted. If any white streaks/lines (stress marks) are seen on a hydraulic disc in the area between the O-ring seating and the permeate channels then this hydraulic disc must be replaced. Membrane cushions to be examined especially in the area where they are in contact with the O-ring seal. If any marks or surface removal is seen then the membrane cushion must be replaced.</p>
<p>Rebuild the module stack with the blocks of discs previously removed. Rebuild as the blocks were removed “first off is last on”. Rebuild using the same procedure for removing using two hands. Check that the Hydraulic-Discs are in correct alignment as shown in fig.6. Check that the O-ring at the bottom of each block is firmly in its correct position. Inspect again the bottom O-ring just before the block is finally positioned.</p>
<p>Complete the assembly of the module with attention to the instructions given in the previous page regarding Hydraulic-Discs alignment and torque loading.</p>
<p>Membrane cushions are not fitted between: The connection flange and the first hydraulic disc. The last hydraulic disc and the end flange.</p>
<p>Fault not found in first 10 Hydraulic-Discs then continue as follows:</p>
<p>Clean the connection flange.</p>
<ul style="list-style-type: none"> • Inspect the connection flange area where the hydraulic disc O-ring will be in contact with, if any erosion is found it must be repaired or the end flange replaced. This seal face must be smooth, free from indents and scratches.
<ul style="list-style-type: none"> • Inspect also the seal bush fitted to the end flange for erosion, if any is found the seal bush must be replaced. The O-ring sealing face must be free from indents and scratches.
<ul style="list-style-type: none"> • Align the connection flange in relation to the HP inlet and outlet with the permeate elbow.
<p>Commence rebuilding the module stack additional clean working surface is now required.</p>
<ul style="list-style-type: none"> • All blocks that have been removed are now lying upside down on your clean working area.
<p style="text-align: center;">The locating pins on the hydraulic disc must face towards the end flange</p>
<ul style="list-style-type: none"> • Now start with the last block of discs removed. <ul style="list-style-type: none"> - Lift off the 1st Hydraulic-Disc and check that Hydraulic-Disc and O-rings are OK. - Place Hydraulic-Discs on clean surface in the reverse position from lifting if off the block (the side now facing upwards is now as it was prior to removal from the stack) - Check the membrane cushion and if OK fit correctly on top of the 1st disc. - Continue in the same way until this block has been rebuilt replacing any components that have been found faulty or damaged.
<ul style="list-style-type: none"> • Continue rebuilding all the blocks in the same way. <ul style="list-style-type: none"> - The blocks should be laid out in sequence for rebuilding “first off last on”
<p>Fault not found in first 10 discs continuation:</p>
<ul style="list-style-type: none"> • When all blocks have been rebuilt then the 1st repaired block should now be placed over the tie rod and

<p>onto the connection flange, before this block is finally positioned recheck that the bottom O-ring is correct.</p>
<ul style="list-style-type: none"> • Note: No membrane cushion between connection flange and 1st hydraulic disc.
<ul style="list-style-type: none"> • The 1st Hydraulic-Disc that is against the connection flange has the locating pins towards the end flange.
<ul style="list-style-type: none"> • This block should have a membrane fitted.
<ul style="list-style-type: none"> • Now fit the 2nd block checking that the bottom O-ring is correct and the alignment marks are correct, refer to fig.6. Fit membrane cushion on top of this block.
<ul style="list-style-type: none"> • Continue replacing all blocks.
<ul style="list-style-type: none"> • No membrane cushion between the end flange and the last Hydraulic-Disc.
<p>Complete the assembly of the module with attention to the instructions of disc alignment and torque loading.</p>
<p>The section “Fault not found in 1st 10 Hydraulic-Discs” applies also to damage caused by “Pressure on permeate line” and “Vacuum in the feed or concentrate lines”.</p> <p>Except for the following additional notes:</p>
<ul style="list-style-type: none"> • This damage is usually found near the connection flange.
<ul style="list-style-type: none"> • There is usually a minimum of 20 membrane cushions punctured when this happens.
<ul style="list-style-type: none"> • Careful inspection of the membrane cushions by holding them up to a strong light must be made to those cushions that show only slight marking.

Membrane Replacement

Having read this section up to here you are now familiar with the DT module its components and the repairing of it. After some time the membrane cushions will have past their working life, permeate output and quality will have deteriorated and the membranes will have to be replaced.

When this is done the module is stripped down all disc O-rings and membrane cushions are discarded. Each hydraulic disc is thoroughly cleaned with a scrubbing brush and domestic detergent and fitted with new O-rings.

**It is advisable to replace the other O-rings when replacing the membranes.
Thoroughly inspect all other components for damage and erosion.**

5.3. The following additional points MUST be noted.

- 1) There are no membrane cushions between the inlet flange and the first hydraulic disc and between the outlet flange and the last hydraulic disc. All other Hydraulic-Discs have membranes between them.
- 2) Always dismantle the module stack in a clean area there should not be any possibility of dust or other fine particles being able to land on the membranes, Hydraulic-Discs or O-rings.
- 3) If only 1 O-ring has been left out during the rebuilding, feed will flow into the permeate channels and the module will have to be stripped to find the fault and rebuilt again.
- 4) If any hydraulic disc are difficult to remove from the tie rod, these should be carefully inspected near the O-ring seating area for stress markings which usually show as a small line or lines of a lighter colour than the disc colour (dirty white colour sometimes).
- 5) Hydraulic discs that are distorted or have stress marks should be replaced.
- 6) O-rings that have any material from the membrane cushion on them should be replaced. These will show as white on the O-ring.
- 7) Membrane cushions that have any marks on the surface should not be used. i.e. surface light to look for any flaws.

- 8) New O-rings should always be lightly pulled between your forefinger and thumb to feed if there are any nicks or cuts on the O-ring.
- 9) New membrane cushions should always be thoroughly checked before using, check that the surface on both side are without any blemish and check that all outside edges are welded.
- 10) Membrane cushions should always be stored in a sealed container and kept in a cool place away from light.
- 11) If an O-ring will not stay in position, it keeps coming out, then pull and stretch it a little. It may help if the O-ring is pressed into position by using lower part of your palm to do this.
- 12) Sometimes the bottom O-ring will not stay in position when a block of discs are being fitted when this happens put a **little** smear of soft soap on the face of the o-ring that will be in contact with the hydraulic disc.
- 13) Never reconnect the high pressure hoses in the wrong flow position i.e. reverse the hose connections. If they are connected in the reverse flow then the module could be damaged.
- 14) Do not allow leakage from the pressure vessel seals or from the high pressure connections to continue for a lengthy period of time as this could cause erosion to the components and they will have to be replaced instead of being repaired.
- 15) The pins on the hydraulic disc must always face the end flange.
- 16) When replacing new membrane cushions always thoroughly inspect them for faults/damage. Look closely for surface scratches that may have been caused during shipping and handling. Do not use any that have surface scratches.

WARNING

- 1-Under no circumstances try to clean the membrane cushions by hand. That is, opening up the module and cleaning each membrane cushion. This will only cause damage to the fragile surface of the membrane cushion as it is very easily scratched.**
- 2- It is strictly forbidden to connect the inlet water of the component and the concentrate pipe in reverse, The wrong feed water flow path through the module will cause damage to the module.**

6. Quality assurance and after-sales service

- 1) From the date of shipment of the goods, the quality assurance period of DT membrane modules is 12 months under normal operating conditions (except for human error, physical blockage, etc.). Under good operation and maintenance conditions, the service life of the membrane is usually 2-3 years, depending on the water quality and cleaning frequency.
- 2) The seller shall provide free technical guidance for quality problems in the use of membrane modules; if the problems cannot be solved on site, the seller will send relevant professional and technical personnel to the site to provide corresponding solutions.
- 3) During the quality guarantee period, if the parts are damaged due to quality reasons, the seller shall repair the parts free of charge, and the seller shall be responsible for free replacement of the parts that cannot be repaired.